

Givvi®
VIVANTE
#CELEBRATELIFE

2, 2.5 & 3 BHK | **KIWALE**



PUNE - MUMBAI - AHMEDABAD

OUR MILESTONES

20+
Years in
Real Estate

14+
Projects
Completed

2+
Million Sq.Ft.
Delivered

2500+
Happy
Families

A CELEBRATION OF OUR LEGACY

We have come a long way... we have much longer to go!

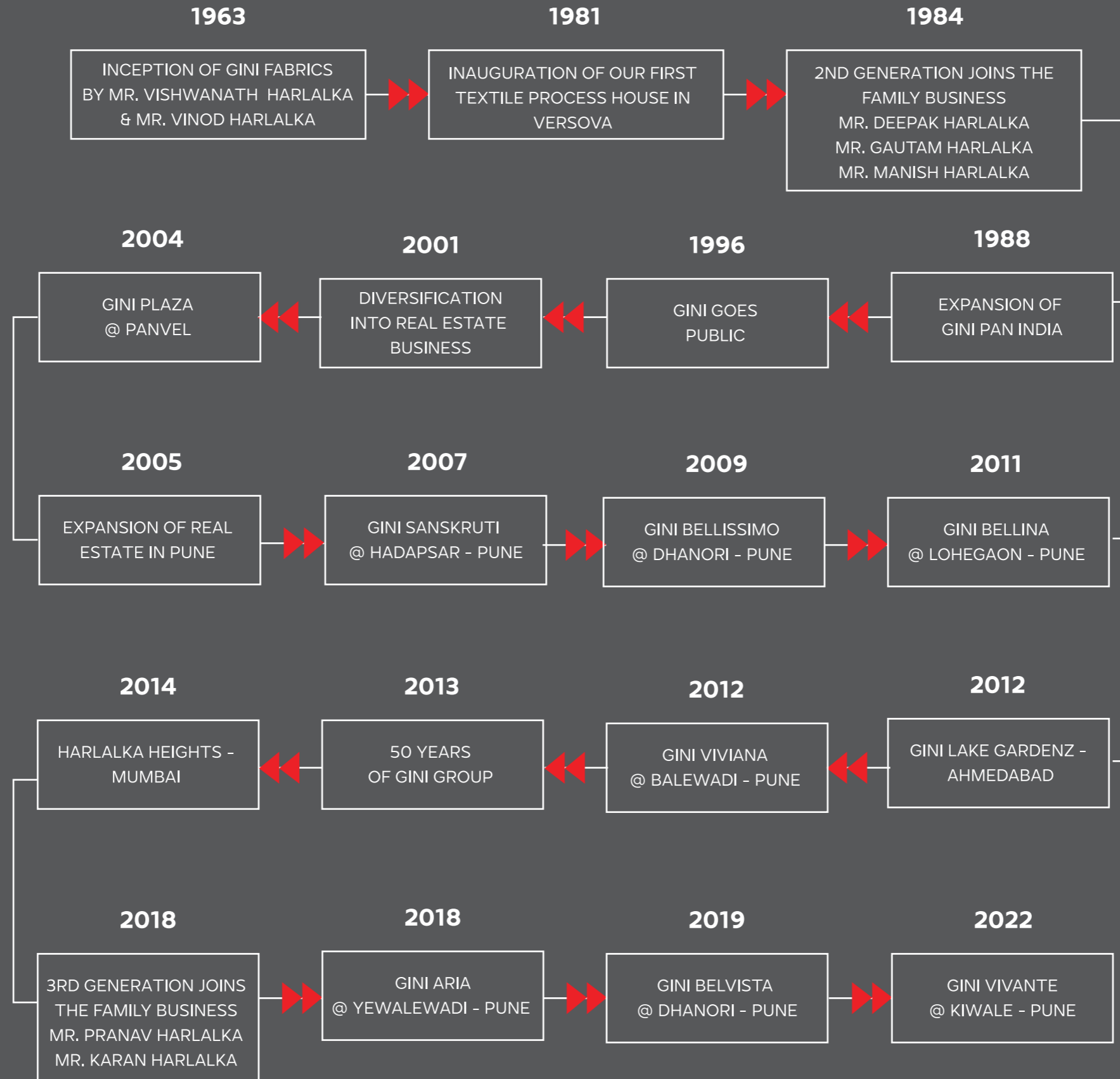



THE CELEBRATION
OF LIFE!

VIVANTE

ARTISTIC IMPRESSION

KIWALE

A DESTINATION OF CELEBRATION

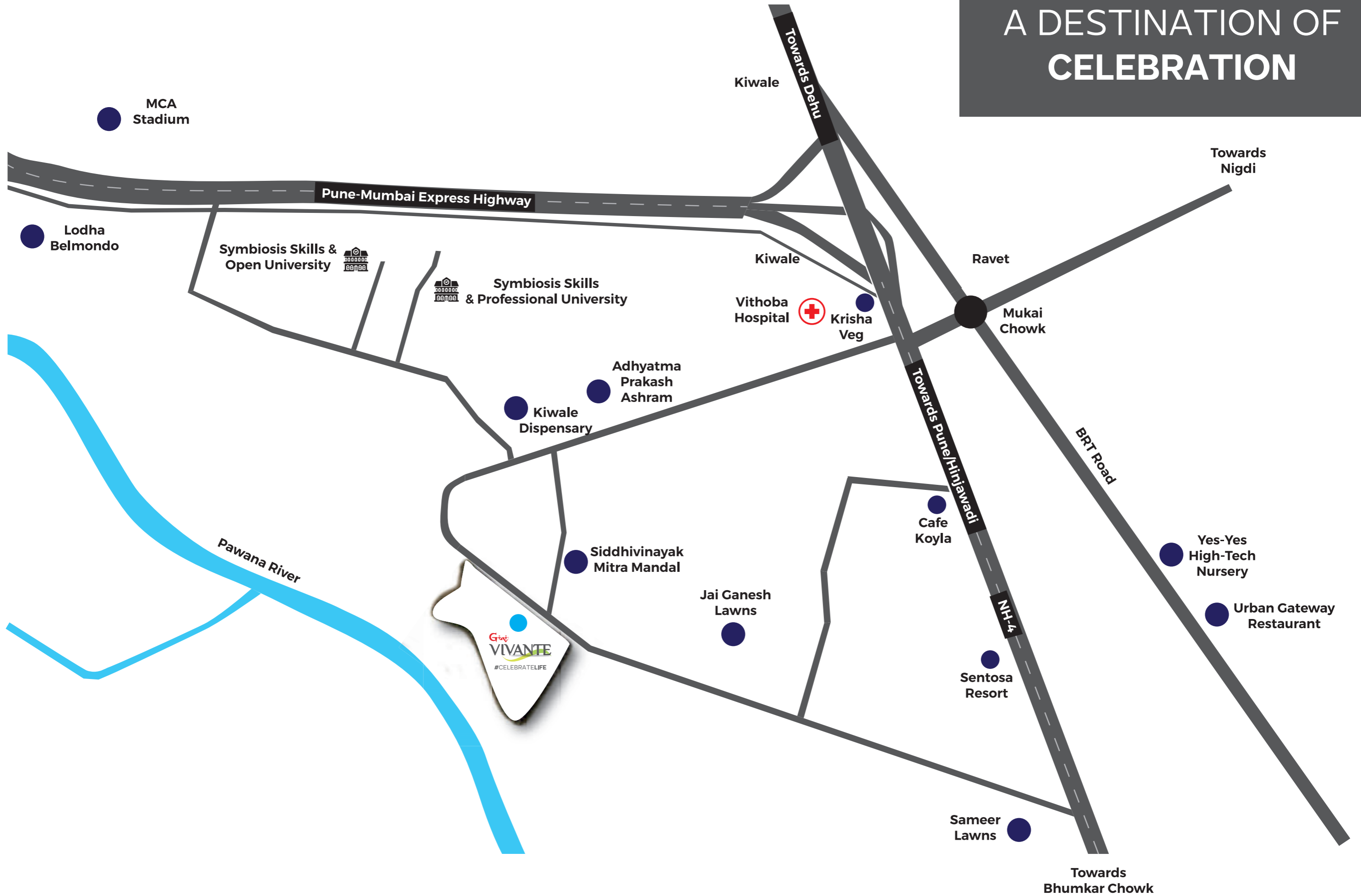

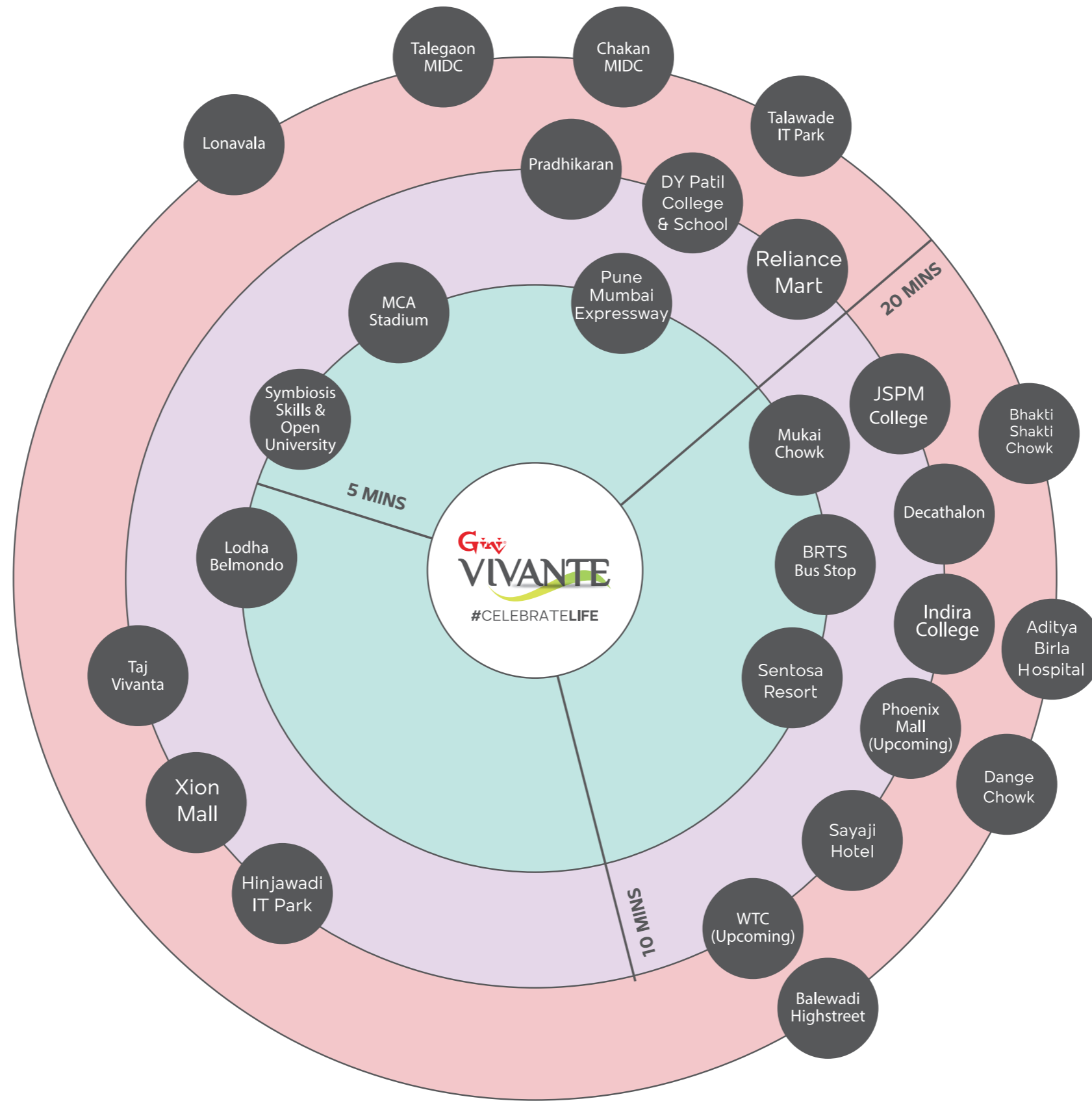



A COLOSSAL 17+ ACRE PROJECT





100+  **LIFESTYLE AMENITIES**

7+  **ACRES OF OPEN AREA**

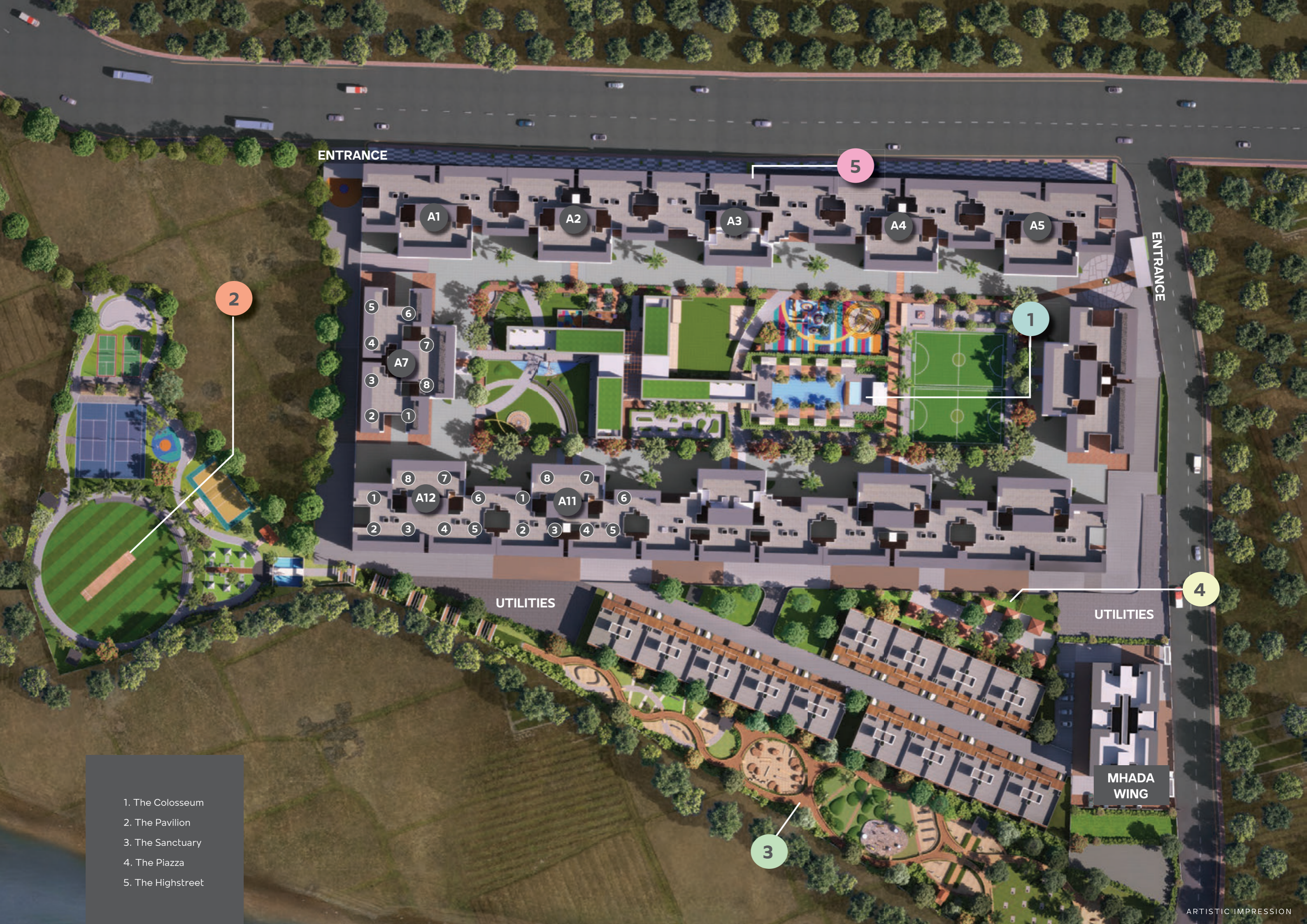

ENTRANCE

ENTRANCE

UTILITIES

UTILITIES

MHADA WING

2

5

1

4

3

A1

A2

A3

A4

A5

A7

A8

A12

A11

- 1. The Colosseum
- 2. The Pavilion
- 3. The Sanctuary
- 4. The Plaza
- 5. The Highstreet



ARTISTIC IMPRESSION

THE COLOSSEUM

THE
GRAND PODIUM

CELEBRATE YOUR LIFESTYLE

Walking Track
Amphitheater
Illuminated Pathway
Party Lawn
Outdoor Cinema
Putting Greens
Cafeteria Deck
Traffic Park
Football Court
Deck Area
Bougainvillea Arbor

Buffet Area
Clock Tower
Flag Hoisting Post
Senior Citizen's Sit out
Feature Wall
Rock-Climbing Wall
Epidium Flooring
Jungle Gym
Outdoor Game Zone
Toddler's Zone
Spider Web

Fully Equipped Play Area
Temperature Controlled
Swimming Pool
Kids Pool
Designer Cabanas
Pool-Side Decks
Dedicated Changing Rooms
Yoga & Meditation Area
Festive Celebration Area
Temple
Multipurpose Court
Children Play Area











ARTISTIC IMPRESSION

CLUB VIVANTE

CELEBRATE
IN STYLE

Table Tennis
Chess
Carron Board
Pool Table
Card Games
Foosball
Shuffle Board
Board Games
Salon
Beauty Parlor
Spa

Steam Room
Crechè
Cafeteria
Dedicated
Changing Rooms
Library/Study Area
Guest Suites
Private Theater
Indoor Gymnasium
Zumba & Pilates Studio
Wi-Fi Zone

Business Centre
Multipurpose Hall
Secure Locker
Open to Sky Yoga Deck
Selfie Point
Teenagers Zone
Managers Room
Drivers Lounge





CLUB
VIVANT

YOGA IS THE PRACTICE
OF QUIETING THE MIND.



ARTISTIC IMPRESSION

THE PAVILION

THE
ACTIVE ARENA

CELEBRATE YOUR PASSIONS

Skating Rink
Badminton Courts - 2
Tennis Courts - 2
Basketball Ring
Sand Pit Area
Beach Volleyball
Cricket Ground
Cycling Track

Jogging Track
Pavilion Seating
Gazebo
Changing Room
Infinity Walkway
Camping Zone
Bonfire Pit



Giv
VIVANTE
CELEBRATE LIFE!









ARTISTIC IMPRESSION

THE SANCTUARY

THE
BLISSFUL ABODE

CELEBRATE YOUR TRANQUILITY

- Forest Trail
- Elevated Pathway
- Acupressure Track
- Oxygen Zone
- Fragrance Path
- Pergola And Trellis with Sit-outs
- Natural Play Area
- Mound Garden
- Dog Park
- Outdoor Gym Area
- Watch Tower
- Musical Garden
- Yoga Zone
- Meditation Zone
- Hammock Zone
- Butterfly Garden











ARTISTIC IMPRESSION

THE PLAZZA

THE
BAZAAR

Vegetable Market
Fruit Grove
Sand Pit Area
Cafeteria with Seating Area
Workshops
Seating plaza

EV Charging Zone
Cycle Station
Herbal Garden
Entrance Plaza
Welcome Fountain



ARTISTIC IMPRESSION

THE HIGHSTREET

THE
SHOPPING ARCADE

100+

+

**LIFESTYLE
AMENITIES**



ALL IMAGES ARE CONCEPTUAL IMAGES



ALL IMAGES ARE CONCEPTUAL IMAGES



ALL IMAGES ARE CONCEPTUAL IMAGES

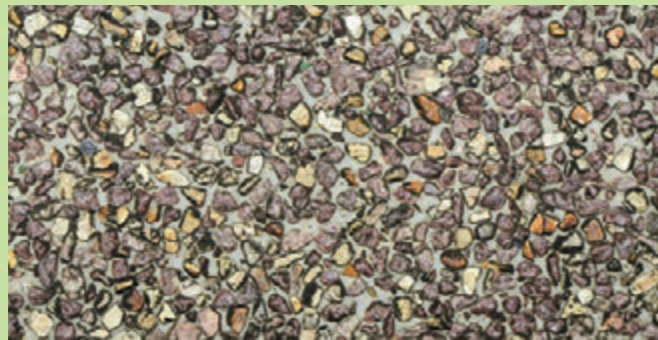

ALL IMAGES ARE CONCEPTUAL IMAGES



ALL IMAGES ARE CONCEPTUAL IMAGES

SPECIFICATIONS



RCC

- Structure Designed with Earthquake Resistant Frame



ELECTRIFICATION

- Concealed Electrical Wiring • Renowned Modular Switches
- Standard ISI Multi Strand Wires with MCB & ELCB
- Provision for AC Points in Living & All Bedrooms
- TV and Telephone Points in Master Bedroom & Living Room



FLOORING

- Wooden Finish Tiles in Master Bedroom
- Vitrified Tiles in the Rest of the Unit
- Dado Tiles for Bathrooms and Kitchen
- Anti-Skid Tiles for Bathroom & Terraces



DOORS

- Laminated Doors with CP fittings



KITCHEN

- Granite Platform
- Stainless Steel Sink
- Dado Tiles up to 2 Feet Height
- Provision for Washing Machine
- Provision for Exhaust Fan
- Provision for Water Purifier



WALL FINISH / PAINT

- O.B.D Paint for Interiors
- Apex Emulsion Paint for Exteriors



WINDOWS

- Granite Windowsills
- Aluminium Windows with Mosquito Net
- Window Grills
- Aluminium Sliding Door for Balcony



BATHROOMS/ TOILETS

- Concealed Plumbing
- Single Lever Diverter
- Health Faucet
- Bathroom Glazing up to 7 Feet Height
- Marble / Granite Door Frames
- Solar Heated Water for Master Bathroom
- Provision for Electric Geyser
- Provision for Exhaust Fan



UTILITIES

- Sewage Treatment Plant
- Organic Waste Converter
- Rainwater Harvesting
- Water Recycling for Garden and Flushing
- Generator Backup for Common Passages / Utilities
- Provision for Inverter in Each Unit
- Fire Fighting System
- Trimix Concrete Roads
- Anti-Termite Treatment for Building Structure
- Underground and Overhead Tanks for Water Storage



SECURITY

- Video Door Phone for Each Unit
- CCTV Cameras for Selected Areas
- Security Cabin
- Access Controlled Main Lobbies
- Boom Barrier

TYPICAL 2 BHK



TYPICAL 2.5 BHK



TYPICAL
3 BHK



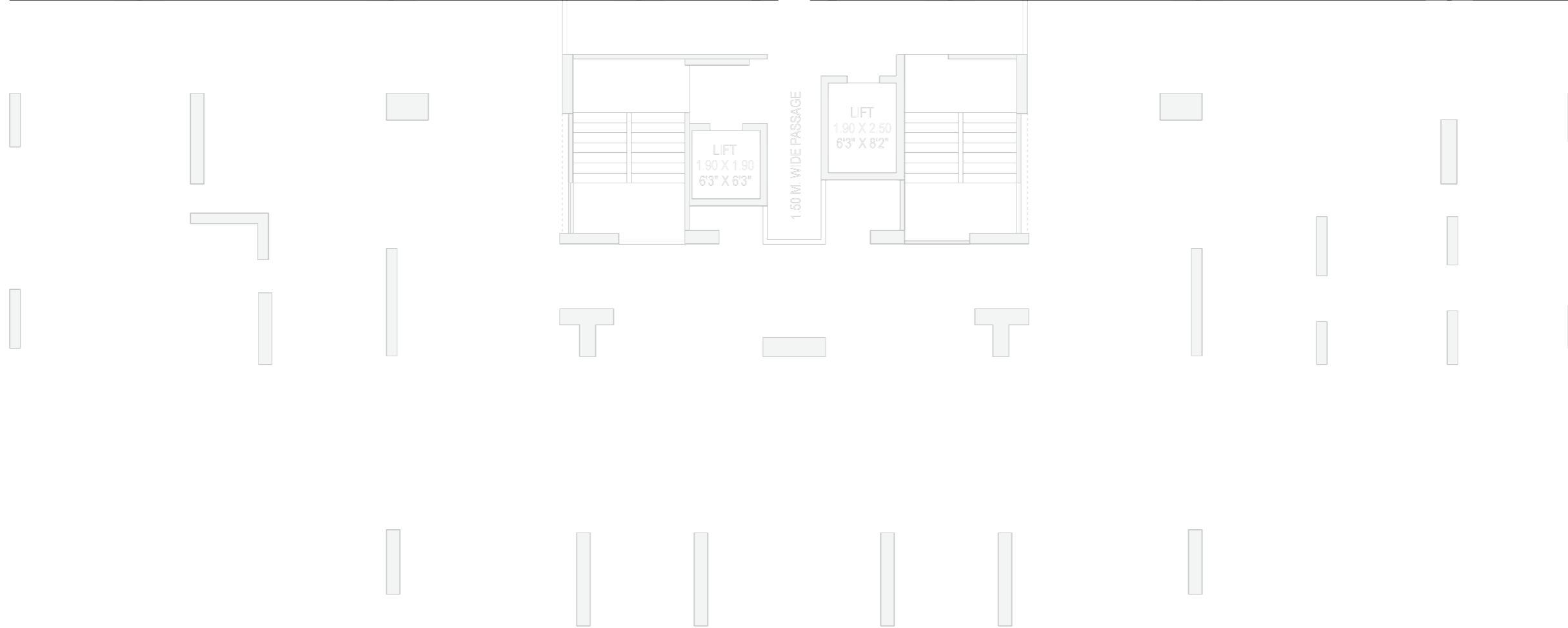
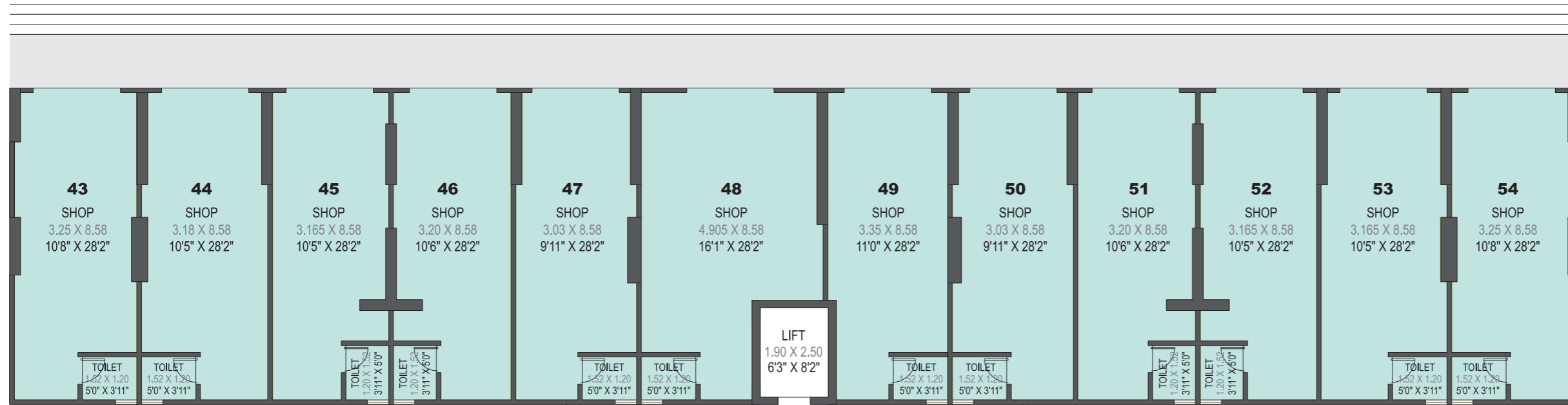

AREA STATEMENT

SHOP NO.	SHOP CARPET	TOTAL CARPET AREA
	SQ.MT.	SQ.FT.
43	28.89	311.00
44	29.37	316.00
45	27.86	300.00
46	28.16	303.00
47	27.93	301.00
48	37.72	406.00
49	28.36	305.00
50	27.93	301.00
51	28.16	303.00
52	27.86	300.00
53	29.24	315.00
54	28.90	311.00

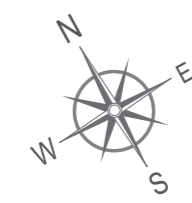

WING A5 | UPPER GROUND FLOOR PLAN

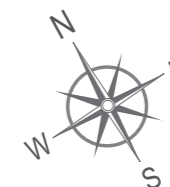
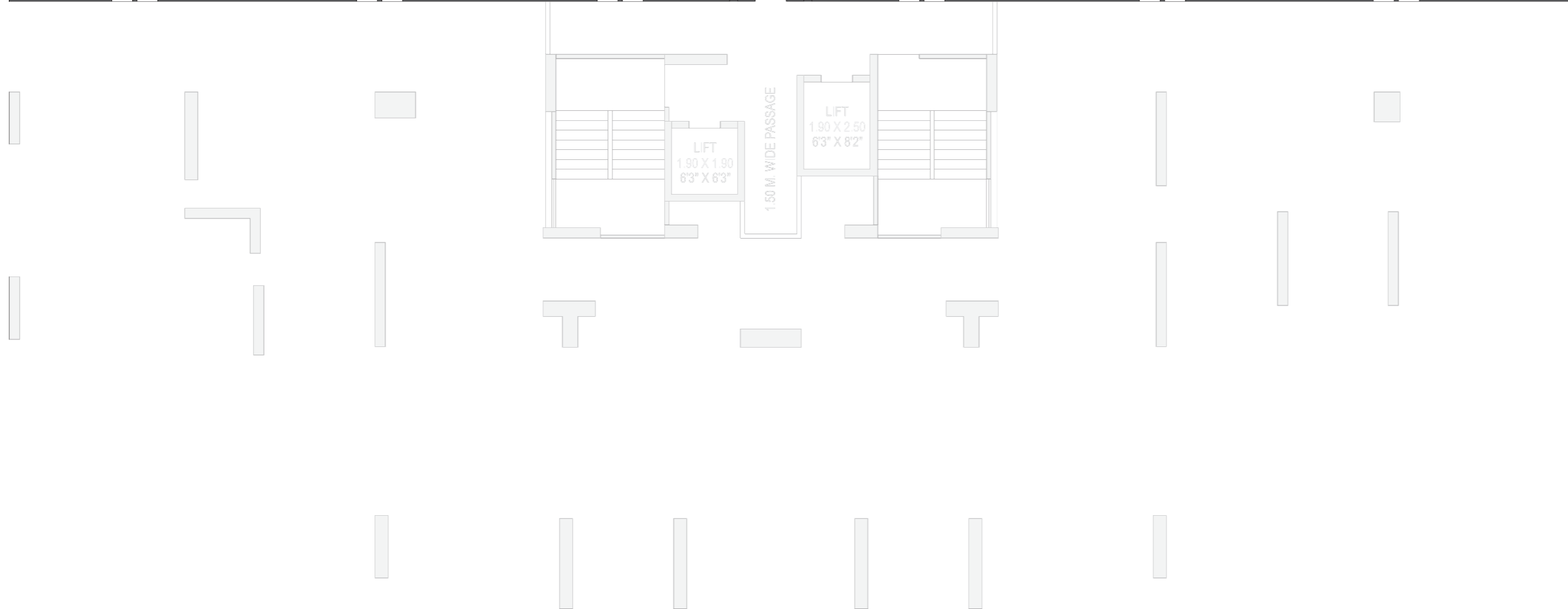
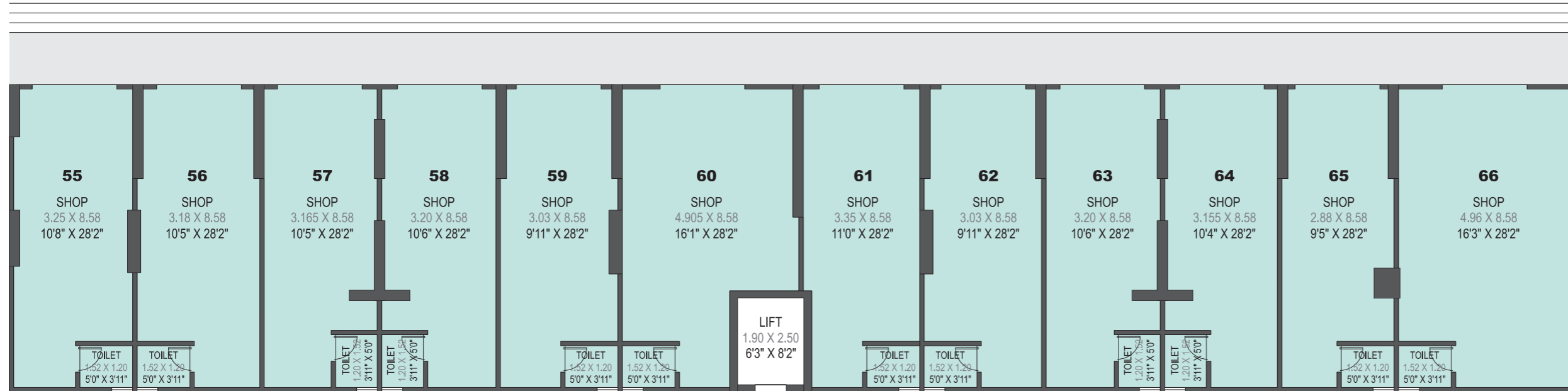

AREA STATEMENT

SHOP NO.	SHOP CARPET	TOTAL CARPET AREA
	SQ.MT.	SQ.FT.
55	28.90	311.00
56	29.50	318.00
57	27.86	300.00
58	28.16	303.00
59	27.93	301.00
60	37.72	406.00
61	28.36	305.00
62	27.93	301.00
63	28.16	303.00
64	27.77	299.00
65	27.11	292.00
66	43.63	470.00

WING A7 | 1ST & 2ND FLOOR PLAN



FLAT NO.	TYPE	CARPET AREA		TOTAL CARPET AREA	
		FLAT CARPET	BALCONY CARPET	SQ.MT.	SQ.FT.
101,201	3 BHK Smart	76.87	5.21	82.08	883.00
102,202	3 BHK Smart	76.87	5.21	82.08	883.00
103,203	2 BHK Luxe	67.22	5.40	72.62	781.00
104,204	2 BHK Luxe	67.22	5.40	72.62	781.00
105,205	3 BHK Smart	76.87	5.21	82.08	883.00
106,206	3 BHK Smart	76.87	5.21	82.08	883.00

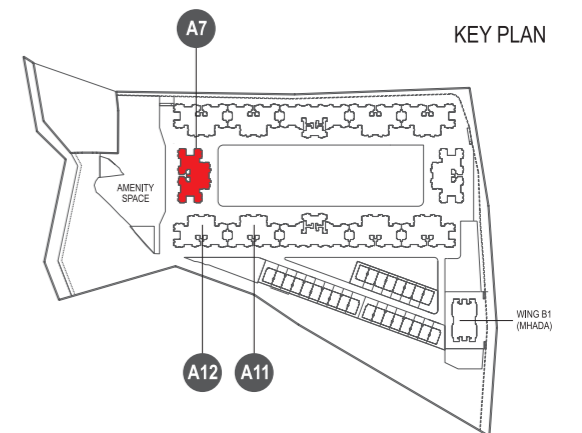

WING A7 | TYPICAL FLOOR PLAN 3RD, 4TH, 5TH, 6TH, 7TH, 9TH, 10TH, 11TH, 13TH, 14TH, 15TH, 17TH, 18TH, 19TH, 20TH, 21ST, 22ND, 23RD, 25TH, 26TH & 27TH FLOOR

**302,402,502,602,702,902,1002,1102,1302,1402,1502,
1702,1802,1902,2102,2202,2302,2502,2602,2702**

**303,403,503,603,703,903,1003,1103,1303,1403,1503,
1703,1803,1903,2103,2203,2303,2503,2603,2703**

**304,404,504,604,704,904,1004,1104,1304,1404,1504,
1704,1804,1904,2104,2204,2304,2504,2604,2704**

**305,405,505,605,705,905,1005,1105,1305,1405,1505,
1705,1805,1905,2105,2205,2305,2505,2605,2705**



**301,401,501,601,701,901,1001,1101,1301,1401,1501,
1701,1801,1901,2101,2201,2301,2501,2601,2701**

**306,406,506,606,706,906,1006,1106,1306,1406,1506,
1706,1806,1906,2106,2206,2306,2506,2606,2706**

**308,408,508,608,708,908,1008,1108,1308,1408,1508,
1708,1808,1908,2108,2208,2308,2508,2608,2708**

**307,407,507,607,707,907,1007,1107,1307,1407,1507,
1707,1807,1907,2107,2207,2307,2507,2607,2707**

FLAT NO.	TYPE	CARPET AREA		TOTAL CARPET AREA	
		FLAT CARPET	BALCONY CARPET	SQ.MT.	SQ.FT.
301 TO 2701	3 BHK Smart	76.87	5.21	82.08	883.00
302 TO 2702	3 BHK Smart	76.87	5.21	82.08	883.00
303 TO 2703	2 BHK Luxe	67.22	5.40	72.62	781.00
304 TO 2704	2 BHK Luxe	67.22	5.40	72.62	781.00
305 TO 2705	3 BHK Smart	76.87	5.21	82.08	883.00
306 TO 2706	3 BHK Smart	76.87	5.21	82.08	883.00
307 TO 2707	3 BHK Spacious	89.41	5.48	94.89	1021.00
308 TO 2708	3 BHK Spacious	89.41	5.48	94.89	1021.00

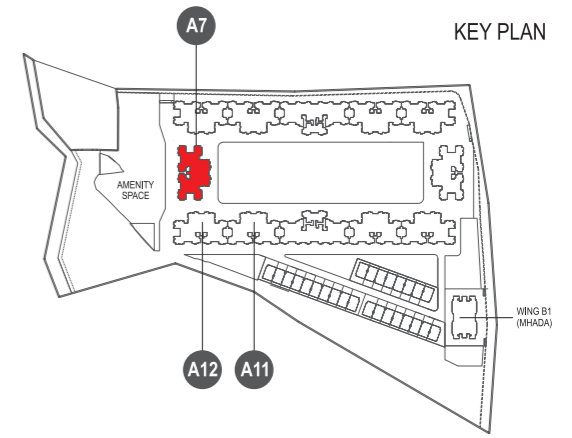

WING A7 | REFUGE 8TH, 12TH, 16TH, 20TH & 24TH FLOOR PLAN



FLAT NO.	TYPE	CARPET AREA		TOTAL CARPET AREA	
		FLAT CARPET	BALCONY CARPET	SQ.MT.	SQ.FT.
801,1201,1601,2001,2401	3 BHK Smart	76.87	5.21	82.08	883.00
802,1202,1602,2002,2402	3 BHK Smart	76.87	5.21	82.08	883.00
803,1203,1603,2003,2403	REFUGE AREA				
804,1204,1604,2004,2404	2 BHK Luxe	67.22	5.40	72.62	781.00
805,1205,1605,2005,2405	3 BHK Smart	76.87	5.21	82.08	883.00
806,1206,1606,2006,2406	3 BHK Smart	76.87	5.21	82.08	883.00
807,1207,1607,2007,2407	3 BHK Spacious	89.41	5.48	94.89	1021.00
808,1208,1608,2008,2408	3 BHK Spacious	89.41	5.48	94.89	1021.00

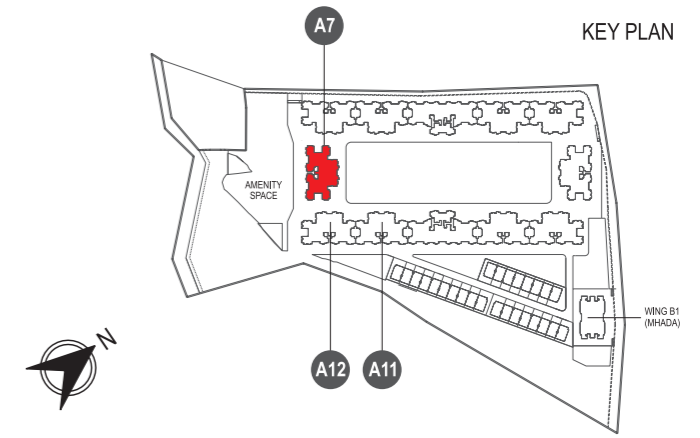

WING A11 | 1ST & 2ND FLOOR PLAN

FLAT NO.	TYPE	CARPET AREA		TOTAL CARPET AREA	
		FLAT CARPET	BALCONY CARPET	SQ.MT.	SQ.FT.
101,201	2 BHK Luxe	68.12	5.10	73.22	788.00
102,202	2 BHK Luxe	67.38	4.86	72.24	777.00
103,203	2 BHK Grande	62.33	4.91	67.24	723.00
104,204	2 BHK Grande	62.33	4.91	67.24	723.00
105,205	2 BHK Luxe	67.38	4.86	72.24	777.00
106,206	2 BHK Luxe	67.63	5.10	72.93	783.00

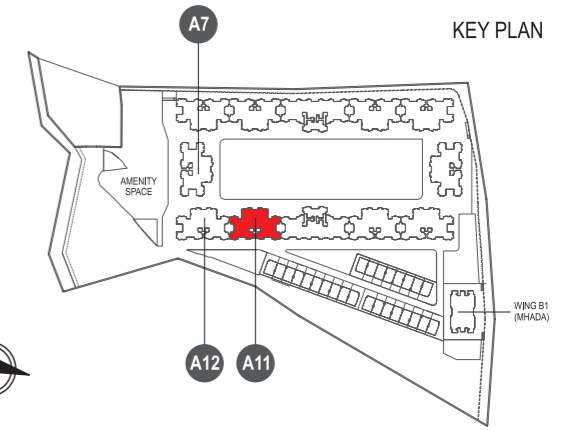

WING A11 | TYPICAL FLOOR PLAN 3RD, 4TH, 5TH, 6TH, 7TH, 9TH, 10TH, 11TH, 13TH, 14TH, 15TH, 17TH, 18TH, 19TH, 20TH, 21ST, 22ND, 23RD, 25TH, 26TH & 27TH FLOOR

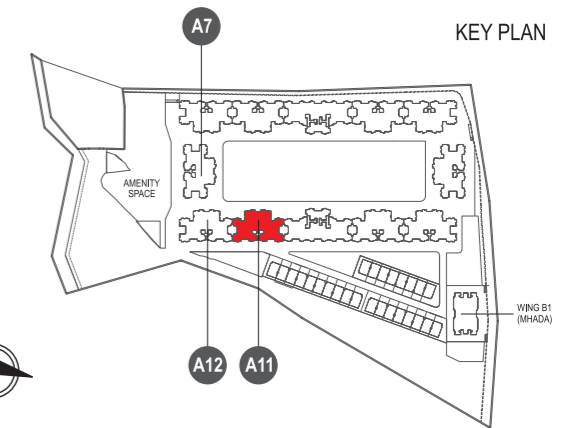

FLAT NO.	TYPE	CARPET AREA		TOTAL CARPET AREA	
		FLAT CARPET	BALCONY CARPET	SQ.MT.	SQ.FT.
301 TO 2701	2 BHK Luxe	68.12	5.10	73.22	788.00
302 TO 2702	2 BHK Luxe	67.38	4.86	72.24	777.00
303 TO 2703	2 BHK Grande	62.33	4.91	67.24	723.00
304 TO 2704	2 BHK Grande	62.33	4.91	67.24	723.00
305 TO 2705	2 BHK Luxe	67.38	4.86	72.24	777.00
306 TO 2706	2 BHK Luxe	67.63	5.10	72.93	783.00
307 TO 2707	3 BHK Spacious	88.25	5.31	93.56	1007.00
308 TO 2708	3 BHK Spacious	88.25	5.31	93.56	1007.00

308,408,508,608,708,908,1008,1108,1308,1408,1508, 1708,1808,1908,2108,2208,2308,2508,2608,2708

307,407,507,607,707,907,1007,1107,1307,1407,1507, 1707,1807,1907,2107,2207,2307,2507,2607,2707

301,401,501,601,701,901,1001,1101,1301,1401,1501, 1701,1801,1901,2101,2201,2301,2501,2601,2701

306,406,506,606,706,906,1006,1106,1306,1406,1506, 1706,1806,1906,2106,2206,2306,2506,2606,2706



302,402,502,602,702,902,1002,1102,1302,1402,1502, 1702,1802,1902,2102,2202,2302,2502,2602,2702

303,403,503,603,703,903,1003,1103,1303,1403,1503, 1703,1803,1903,2103,2203,2303,2503,2603,2703

304,404,504,604,704,904,1004,1104,1304,1404,1504, 1704,1804,1904,2104,2204,2304,2504,2604,2704

305,405,505,605,705,905,1005,1105,1305,1405,1505, 1705,1805,1905,2105,2205,2305,2505,2605,2705

WING A11 | REFUGE 8TH, 12TH, 16TH, 20TH & 24TH FLOOR PLAN

FLAT NO.	TYPE	CARPET AREA		TOTAL CARPET AREA	
		FLAT CARPET	BALCONY CARPET	SQ.MT.	SQ.FT.
801,1201,1601,2001,2401	2 BHK Luxe	68.12	5.10	73.22	788.00
802,1202,1602,2002,2402	2 BHK Luxe	67.38	4.86	72.24	777.00
803,1203,1603,2003,2403	REFUGE AREA				
804,1204,1604,2004,2404	2 BHK Grande	62.33	4.91	67.24	723.00
805,1205,1605,2005,2405	2 BHK Luxe	67.38	4.86	72.24	777.00
806,1206,1606,2006,2406	2 BHK Luxe	67.63	5.10	72.93	783.00
807,1207,1607,2007,2407	3 BHK Spacious	88.25	5.31	93.56	1007.00
808,1208,1608,2008,2408	3 BHK Spacious	88.25	5.31	93.56	1007.00

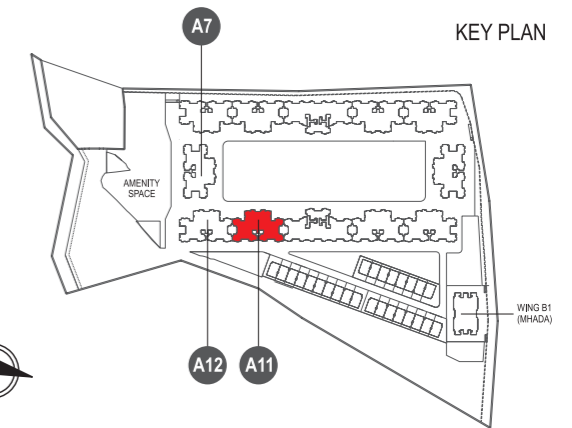

WING A12 | 1ST & 2ND FLOOR PLAN

FLAT NO.	TYPE	CARPET AREA		TOTAL CARPET AREA	
		FLAT CARPET	BALCONY CARPET	SQ.MT.	SQ.FT.
101,201	3 BHK Smart	75.31	4.85	80.16	862.00
102,202	3 BHK Smart	75.31	4.85	80.16	862.00
103,203	2 BHK Grande	62.45	4.91	67.36	725.00
104,204	2 BHK Grande	62.45	4.91	67.36	725.00
105,205	2 BHK Luxe	67.64	4.86	72.50	780.00
106,206	2 BHK Luxe	67.40	5.10	72.50	780.00

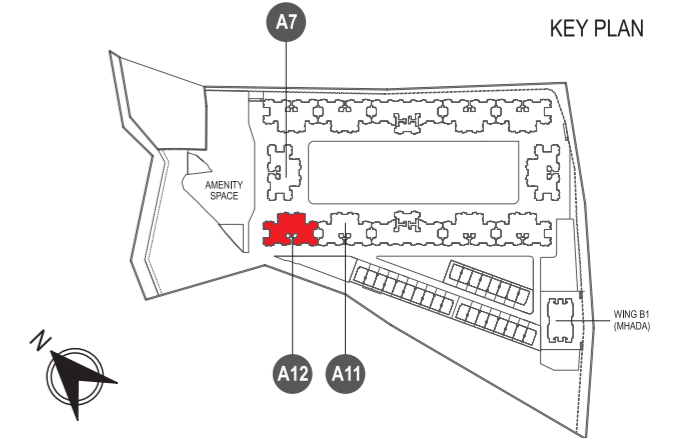

WING A12 | TYPICAL FLOOR PLAN 3RD, 4TH, 5TH, 6TH, 7TH, 9TH, 10TH, 11TH, 13TH, 14TH, 15TH, 17TH, 18TH, 19TH, 20TH, 21ST, 22ND, 23RD, 25TH, 26TH & 27TH FLOOR

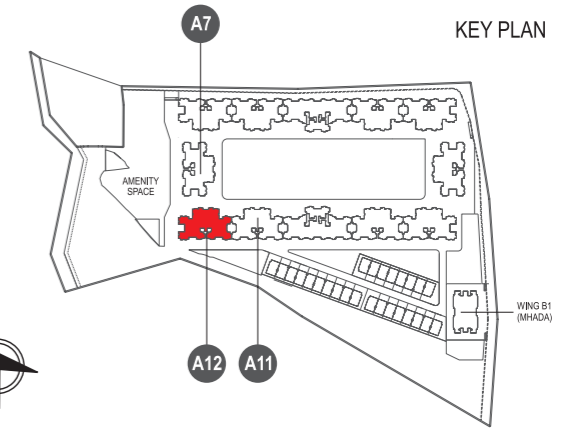

FLAT NO.	TYPE	CARPET AREA		TOTAL CARPET AREA	
		FLAT CARPET	BALCONY CARPET	SQ.MT.	SQ.FT.
301 TO 2701	3 BHK Smart	75.31	4.85	80.16	862.00
302 TO 2702	3 BHK Smart	75.31	4.85	80.16	862.00
303 TO 2703	2 BHK Grande	62.45	4.91	67.36	725.00
304 TO 2704	2 BHK Grande	62.45	4.91	67.36	725.00
305 TO 2705	2 BHK Luxe	67.64	4.86	72.50	780.00
306 TO 2706	2 BHK Luxe	67.40	5.10	72.50	780.00
307 TO 2707	3 BHK Spacious	88.25	5.29	93.54	1006.00
308 TO 2708	3 BHK Spacious	88.25	5.29	93.54	1006.00

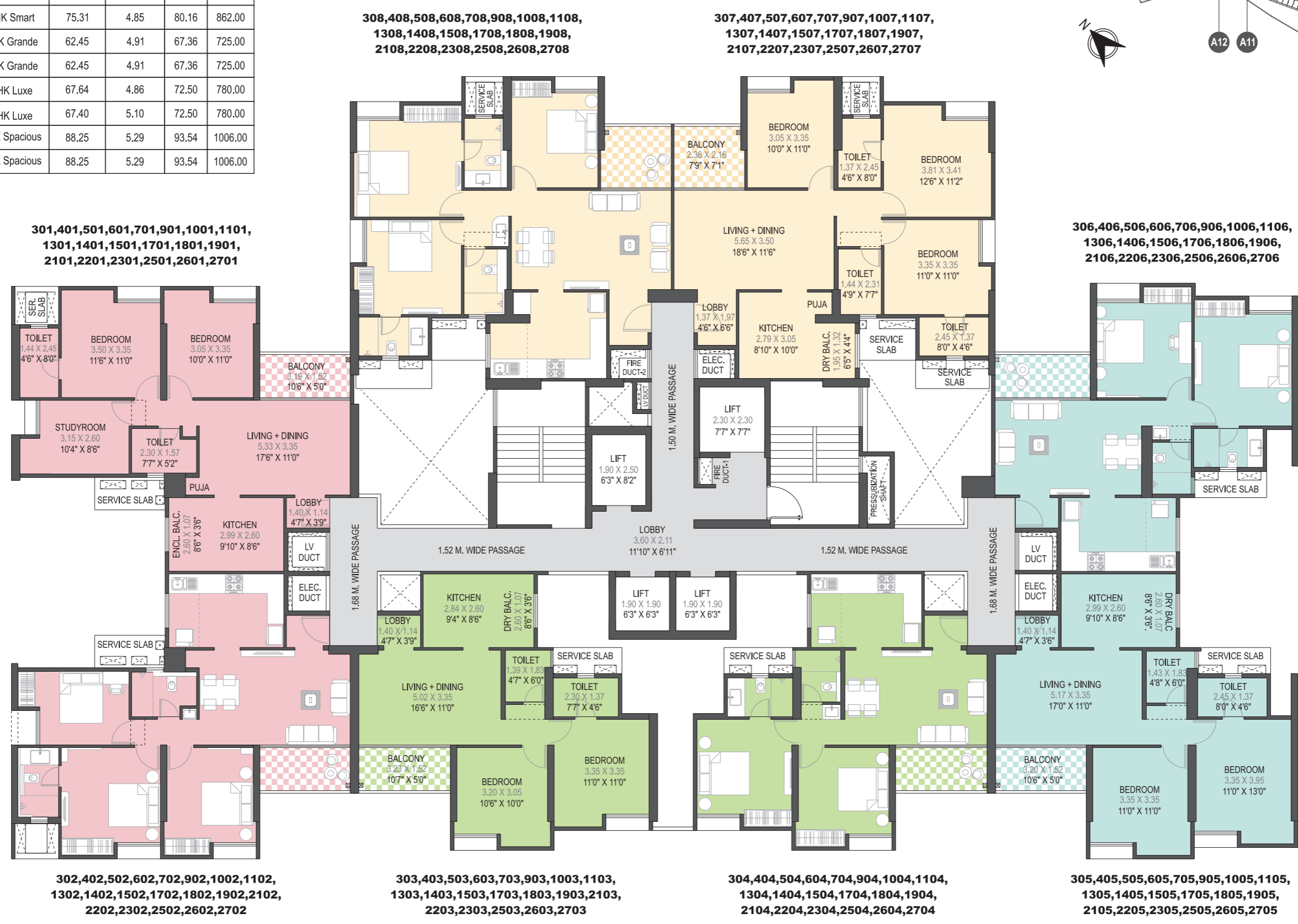

WING A12 | REFUGE 8TH, 12TH, 16TH, 20TH & 24TH FLOOR PLAN

FLAT NO.	TYPE	CARPET AREA		TOTAL CARPET AREA	
		FLAT CARPET	BALCONY CARPET	SQ.MT.	SQ.FT.
801,1201,1601,2001,2401	3 BHK Smart	75.31	4.85	80.16	862.00
802,1202,1602,2002,2402	3 BHK Smart	75.31	4.85	80.16	862.00
803,1203,1603,2003,2403	REFUGE AREA				
804,1204,1604,2004,2404	2 BHK Grande	62.45	4.91	67.36	725.00
805,1205,1605,2005,2405	2 BHK Luxe	67.64	4.86	72.50	780.00
806,1206,1606,2006,2406	2 BHK Luxe	67.40	5.10	72.50	780.00
807,1207,1607,2007,2407	3 BHK Spacious	88.25	5.29	93.54	1006.00
808,1208,1608,2008,2408	3 BHK Spacious	88.25	5.29	93.54	1006.00

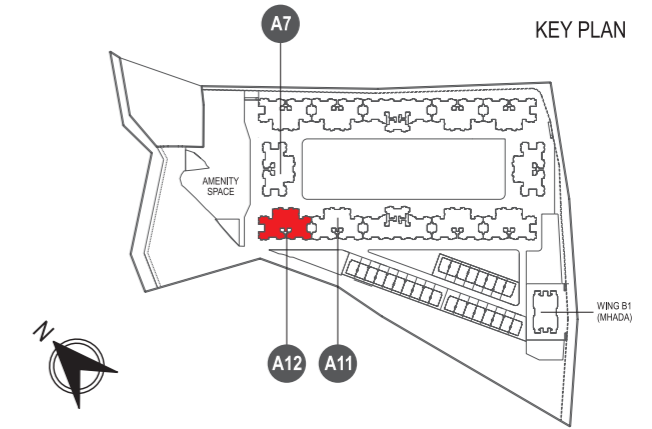

TEAM VIVANTE

Imran Shaikh: Principal Architect

We have a set of quality objectives, environment and design guidelines which we have religiously adhered to while executing and designing this project. Due to this practice of our firm many of our projects have been awarded different architectural awards from various faculties.

Vaishali & Mahesh Chinchalkar: Landscape Consultants

Each piece of land speaks a different language. We, Vaishali and Mahesh, respect the function of the land and design the projects accordingly. We are known for thoughtful and creative designs, which are also sustainable as per the suitability of the site conditions and environment. Our design emerges from experimental art forms to give each project a unique identity. Being artists, we have artfully crafted this project to serve the purpose of connecting people, culture and nature with each other.

Aqueelur Haneef: Structural Consultant

We endeavour to transpire dreams into reality. We aspire to enhance sustainable structural solutions with creativity, commercial awareness, excellent mathematical, IT & analytical skills along with project & budget management expertise. Our continued diligence, economical, practical design solutions and services have enabled us in realizing dreams and strengthening the bonds with our esteemed clientele.

Narendra Chavan: MEP Consultant

Mr. Chavan has a vast experience of 20 years across varied fields like Electrical Power System Design, HT & LT Power Distributions for Industrial Units, Process Industries, Commercial Malls, Office Spaces, Data Centers, Hospitals, along with Mega Township projects. He also has offshore project handling experience in Manchester, UK.

A Project By



GINI CITICORP REALTY LLP

&

WINDSOR TOWN & COUNTRY
(INDIA) PVT LTD

PRAVIN DADABHAU
GAIKWAD

SITE ADDRESS:

Survey no. 91/1, Behind Sameer Lawns, Kiwale Pune – 412101

ADMIN OFFICE:

3E, Gulmohar Apartment, 1st Floor, C Wing, 2420, East Street, Camp, Pune 411 001

Tel: (020) 48617192 Email: crm.vivante@giniconstructions.com

CORPORATE OFFICE

421 Jogani Industrial Premises, Off. N. M. Joshi Marg, Lower Parel (E), Mumbai - 400 011

Website: www.giniconstructions.com

Mobile No.: **7538000444 - 8980001888**

Email Id: vivante.sales@giniconstructions.com



Maharera No.: PHASE 01 - P52100034447 | PHASE 02 - P52100050601 | <https://maharera.mahaonline.gov.in>

Disclaimer: The developer does not warrant the veracity, adequacy or completeness of the information, text, graphics or other material presented in this brochure and expressly disclaim liability for errors and/or omissions, if any. The information depicted herein viz., Furniture layout, fittings, illustrations, specifications, designs, dimensions, rendered views, colours, master plans, floor plans, amenities and facilities, etc., are subject to change without notification as may be required by relevant authorities or the developer's architects, and cannot form part of an offer or contract. All illustrations, pictures and contents are purely conceptual and for representation purpose only and have no legal binding on us. In no event will the developer be liable for any incidental or consequential damages, arising in connection with this display or use thereof or inability to use by any party. The developer is wholly exempt from any claim in this regard.